

# SpinSR10

Super Resolution for All Types of Live Cell Imaging

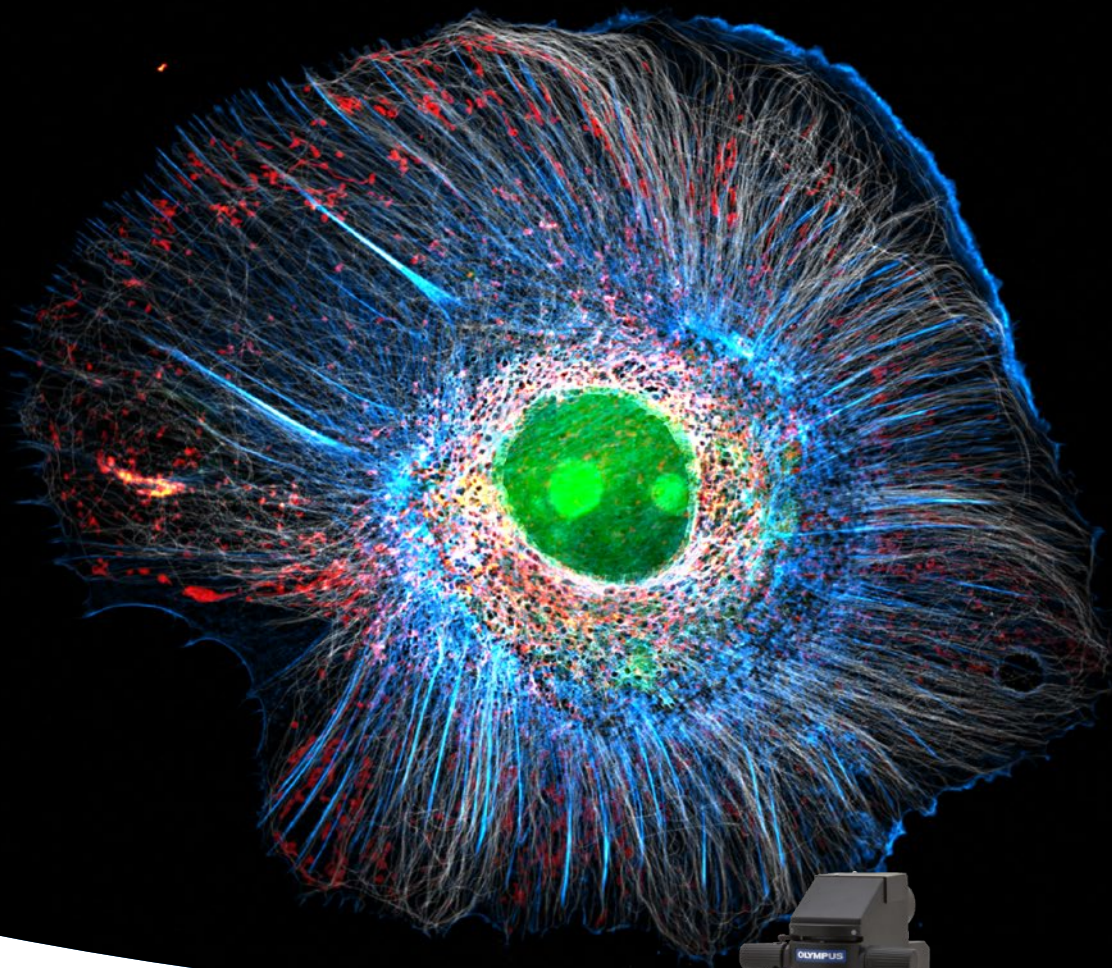

**EVIDENT**

# Higher Level of Super Resolution Imaging

Designed for live cell imaging with 120-nanometer resolution, the SpinSR10 super resolution imaging system balances speed, resolution, and efficiency in a single, flexible platform. Researchers can observe the fine details and dynamics of cellular structures and processes with the ability to easily switch between super resolution, confocal, and widefield imaging. The system's advanced confocal technology enables researchers to capture super resolution images with excellent clarity.

## Olympus Super Resolution

Olympus super resolution (OSR) technology is fast, easy to use, and can provide images from up to 100 microns deep within a cell in areas that are hard to access using other super resolution modes. Live cell super resolution images of internal cellular structures can be captured with 120 nm resolution from all kinds of samples using conventional fluorescent dyes. Processing on a single confocal image achieves super resolution imaging with minimum data volume as well as high speed.

Reference: S. Hayashi, "Resolution Doubling Using Confocal Microscopy Via Analogy With Structured Illumination Microscopy". Jpn J Appl Phys. (2016)

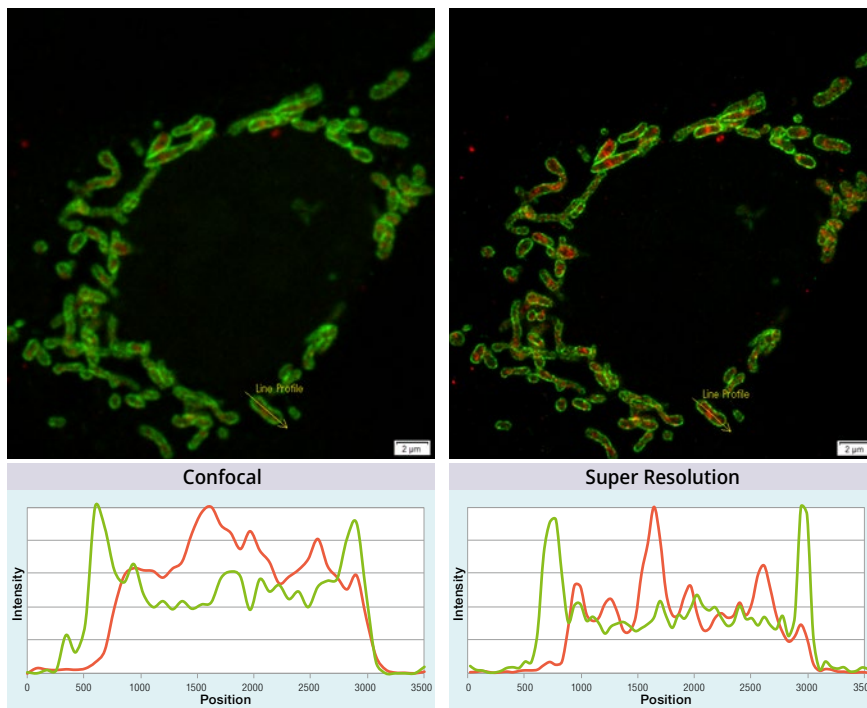

Images of two adjacent emission points  
(• emission point)

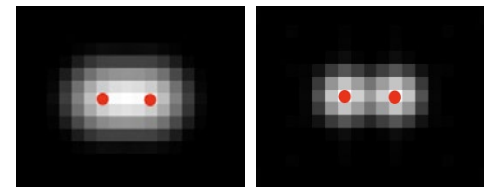

Principle of OSR

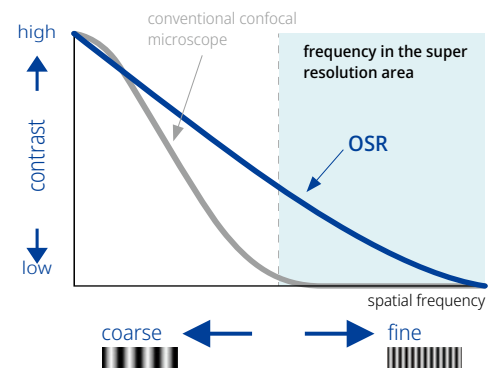

## Dedicated Magnification Changer

Our dedicated magnification changer delivers even illumination across the entire field of view. The changer's telecentric optical system optimized for the IX83P2ZF inverted microscope maximizes the performance of the objectives during confocal and super resolution imaging while enabling seamless switching between confocal and super resolution.



Motorized Magnification Changer

## Fast Super Resolution Imaging and a Wide Field of View

Instead of painstakingly scanning the entire field of view, the sensitive imaging sensor on the SpinSR10 system captures snapshots of the entire sample area in one step for fast imaging, enabling researchers to observe high-speed biological phenomena. In widefield and confocal mode, the microscope's optical system has a field number (FN) of 18 to capture images with a larger field of view, while two cameras enable users to simultaneously acquire dual-color super resolution images.

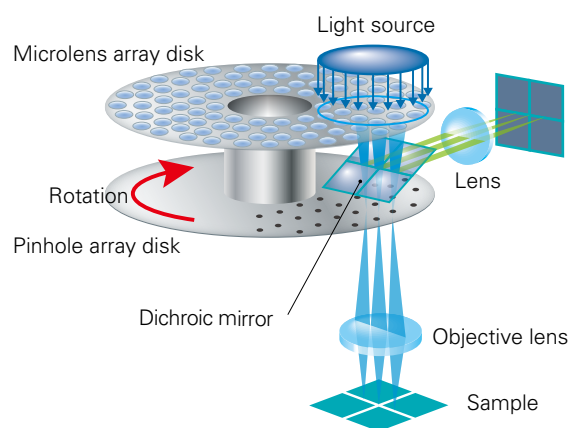

## Spinning Disk Delivers Bright Live Cell Imaging

Each confocal pinhole on the disk has a microlens that enables you to image with lower laser power, reducing photobleaching and phototoxicity in your sample while enabling bright super resolution images.

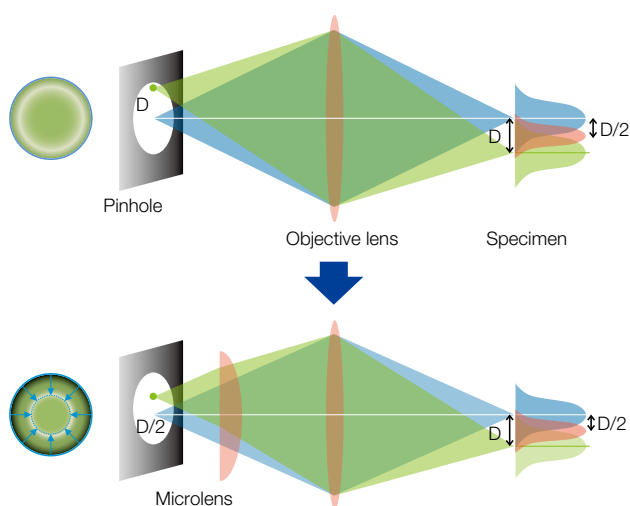

Principle and configuration of CSU-W1 with SoRa disk

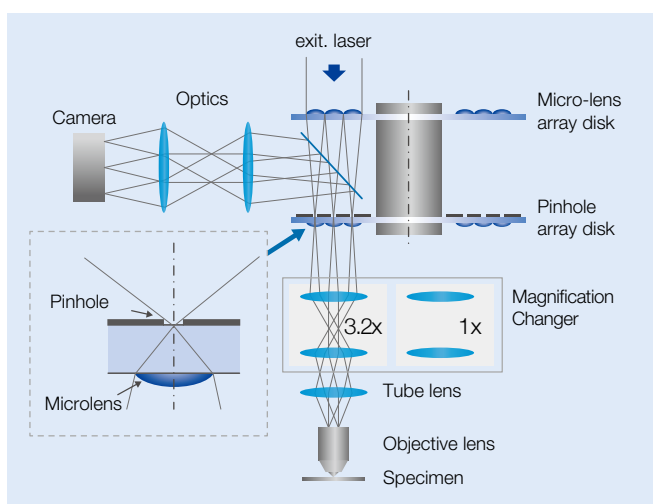

In regular confocal microscopes, image formation is a product of the illumination point spread function (PSF) and detection PSF. Looking at the image formation on the pinhole at position  $D$  from the optical axis, it is the product of the illumination PSF and detection PSF, and we can see that information from position  $D/2$  from the optical axis is transmitted but not resolved. To correct this, a microlens is fitted in the pinhole, and the individual focal points projected onto the pinhole are optically reassigned to the center, creating an ideal image and increasing the brightness and resolution. This process makes the resolution nearly equal to that of an ideal confocal microscope in which the pinhole has been reduced to an infinitesimal size.

Reference: T. Azuma and T. Kei, "Super-Resolution Spinning-Disk Confocal Microscopy Using Optical Photon Reassignment," *Opt. Express* 23, 15003-15011. (2015)

# Live Cell Super Resolution Imaging

The SpinSR10 system combines speed, reduced phototoxicity, and stability during time-lapse experiments to create 3D super resolution data that enables users to observe dynamic changes and phenomena within live cells.

## Live Super Resolution

The spinning disk confocal optical system acquires live super resolution images at up to 200 frames per second.

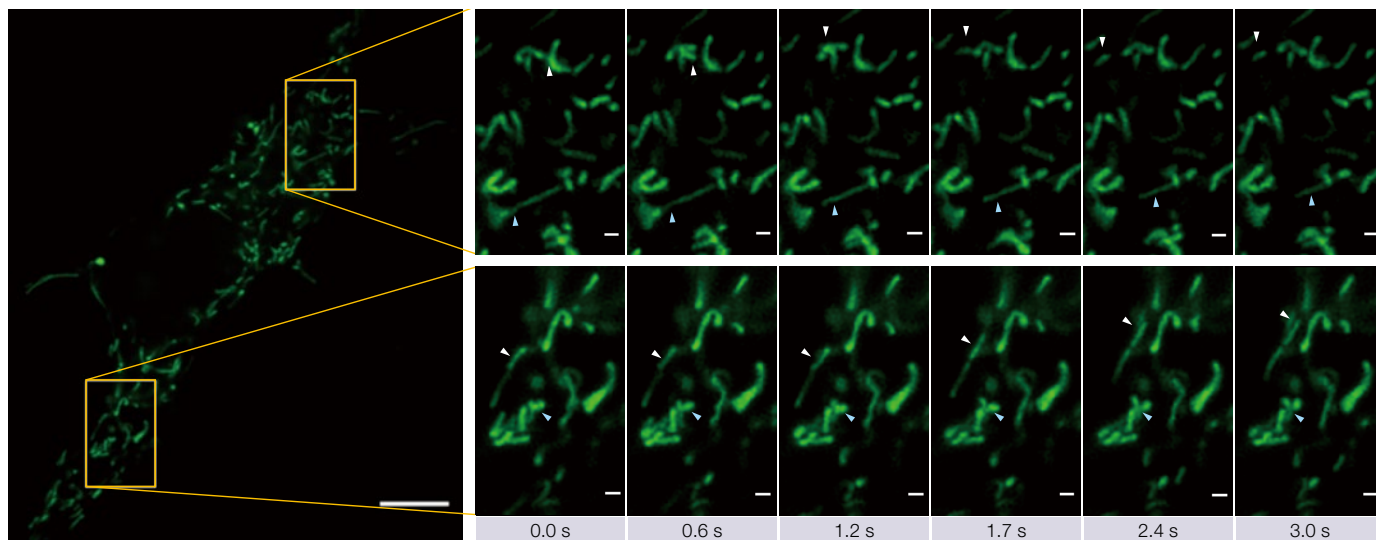
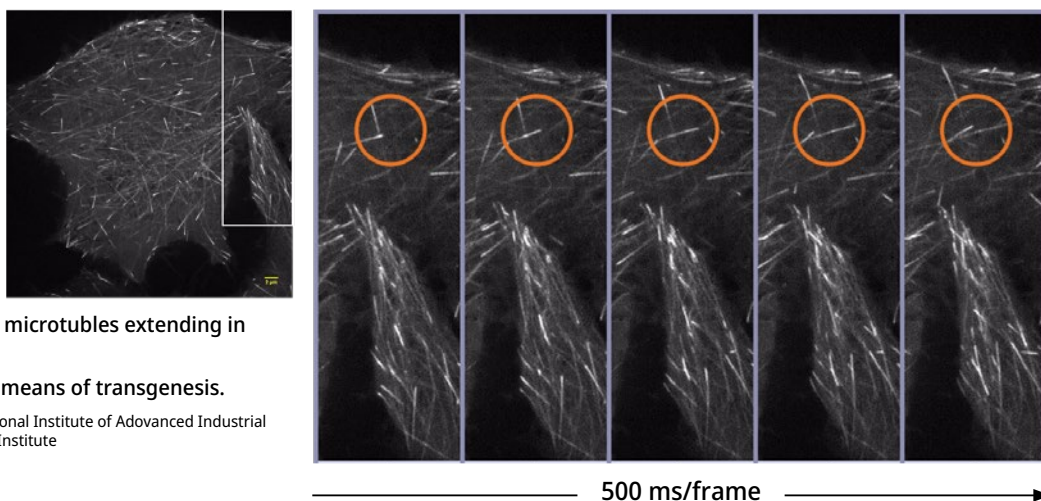

Image of mitochondria obtained at 30 fps

Mitochondria labeled by GFP. Acquired at 30 fps, can see the individual mitochondria movements.  
Image data courtesy of: Kumiko Hayashi, PhD, Graduate School of Engineering, Tohoku University

## Real-Time Super Resolution

High-speed data processing algorithms enable the viewing of super resolution images in a live display window. This enables real-time viewing of cellular activities compared to other computational super resolution techniques that require post processing before a super resolution image can be displayed.



EB3 proteins binding to the top of microtubules extending in HeLa live cells.

EB3 proteins were GFP-labeled by means of transgenesis.

Image data courtesy of: Kaoru Kato, PhD, National Institute of Advanced Industrial Science and Technology Biomedical Research Institute

## Two-Color Simultaneous Imaging

The SpinSR10 system can use two cameras simultaneously to provide fast, two-color localization imaging.

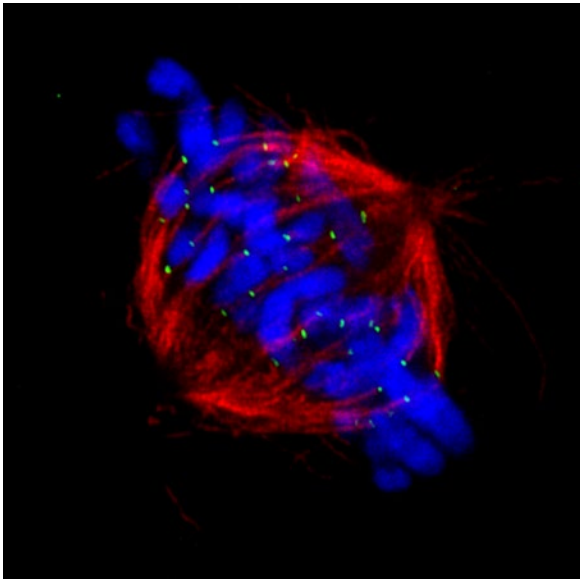

**Mitotic spindle at metaphase cell**

HeLa cells derived from human cervical cancer were fixed and stained for  $\alpha$ -tubulin (microtubules, red) and Hec1 (kinetochores, green), respectively. DNA was stained with DAPI (chromosomes, blue). Chromosomes interact with microtubules constituting mitotic spindle via kinetochores assembled on the centromere region of chromosomes.

Image data courtesy of: Masanori Ikeda and Kozo Tanaka, Department of Molecular Oncology, Institute of Development, Aging and Cancer

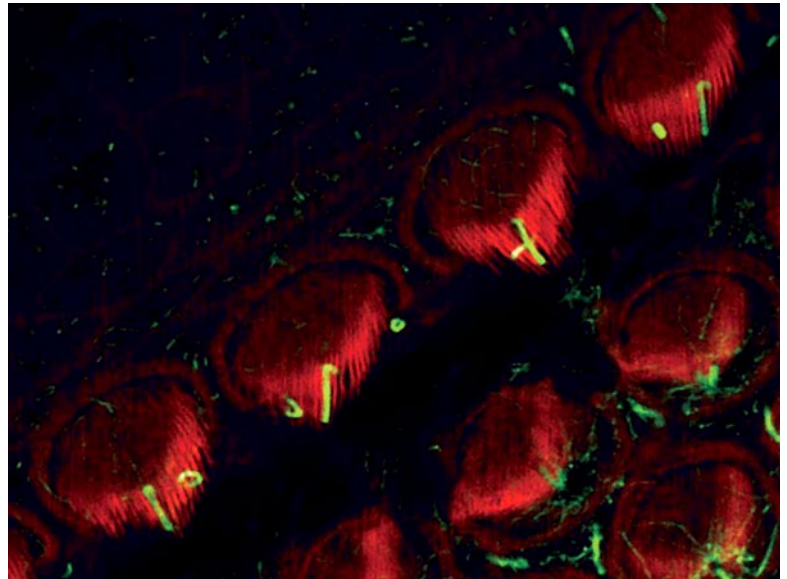

**Stereocilia and kinocilia of inner hair cells in the organ of Corti (actin: orange, tubulin: green):**

Image data courtesy of: Hatsuho Kanoh<sup>1</sup>, Toru Kamitani<sup>1,2</sup>, Hirofumi Sakaguchi<sup>2</sup>, Sachiko Tsukita<sup>1</sup>  
<sup>1</sup> Graduate School of Frontier Biosciences and Graduate School of Medicine, Osaka University  
<sup>2</sup> Department of Otolaryngology-Head and Neck Surgery, Kyoto Prefectural University of Medicine

## Keep Your Samples in Focus

During time-lapse imaging, minute changes in temperature, humidity, and other factors can cause your sample to go out of focus. The TruFocus™ Z-drift compensator uses a low phototoxicity infrared laser to identify the sample plane and adjust the focus for clear time-lapse images. The continuous autofocus function works with glass and even plastic vessels.

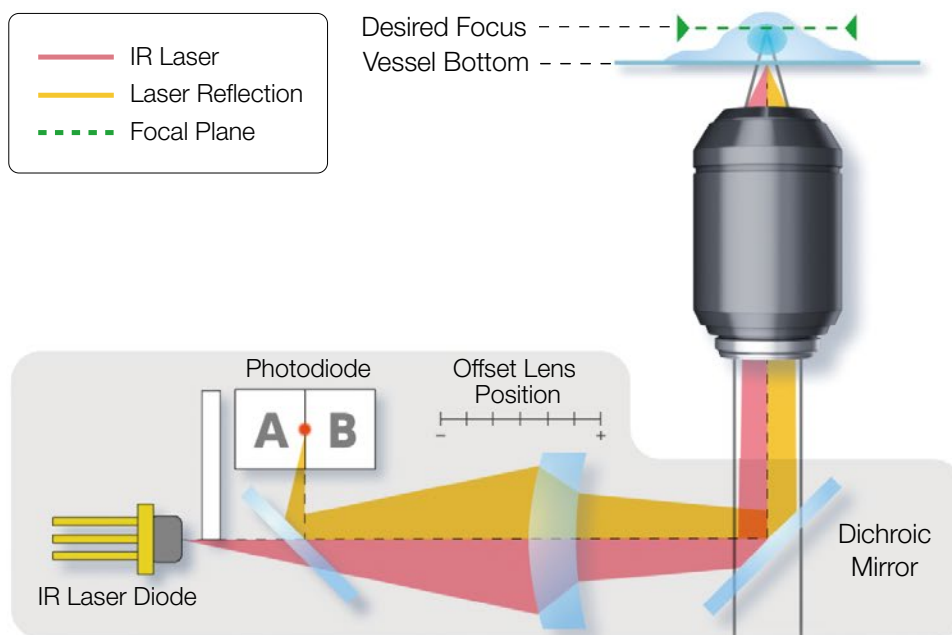

# See Inside Your Samples in Super Resolution

## Observation at Depth

Clearly observe small individual spines on the surface of the sample and up to 100 microns deep within the sample.

### Purkinje cells labeled with GFP

XYZ image with confocal and super resolution image in different Z positions. Super resolution images are projected by Z (10 slices). 3D displayed by FV31S-DT.

Image data courtesy of: Yukari Takeo, Michisuke Yuzaki, PhD, Department of Physiology, School of Medicine, Keio University

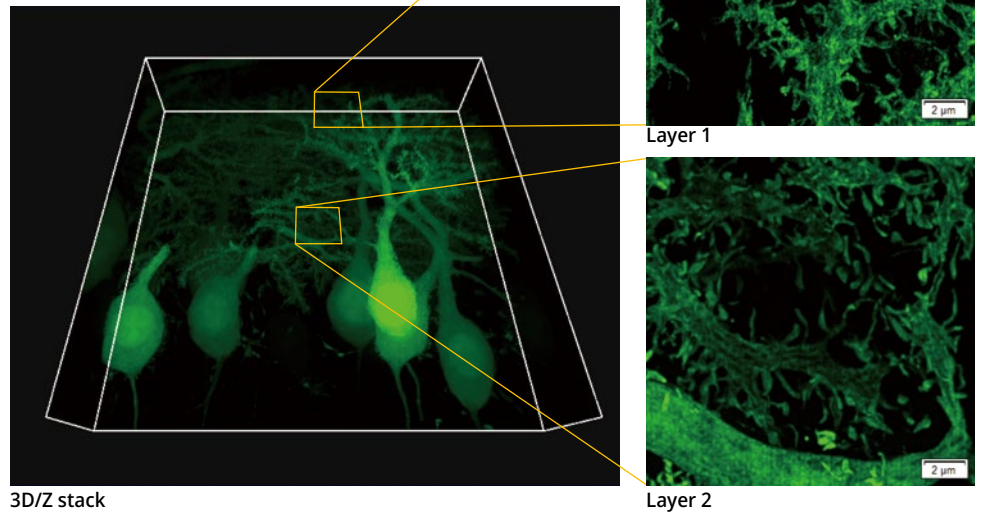

## Image Three-Dimensional Structures

Obtain detailed three-dimensional super resolution image data during time-lapse imaging.

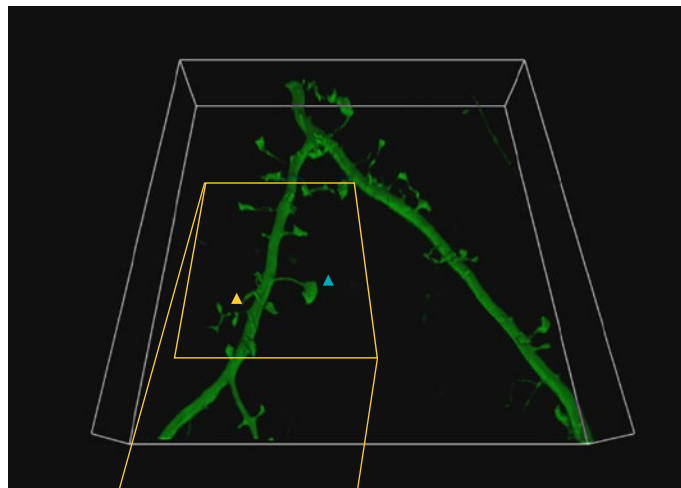

### 3D time-lapse of a neuron

Time-lapse image of a mouse primary neuron labeled with EGFP after co-culture with astrocyte for 2 weeks. It is easy to see the difference between the immature spine (yellow arrow) and mature spine (blue arrow), as well as detect the morphological change in time.

The 3D image was acquired with the exposure time of 500 ms/frame, 0.15 µm Z-step for 41 slices.

Image data courtesy of:  
Yuji Ikegaya, PhD  
Laboratory of Chemical Pharmacology, Graduate School of Pharmaceutical Sciences,  
The University of Tokyo

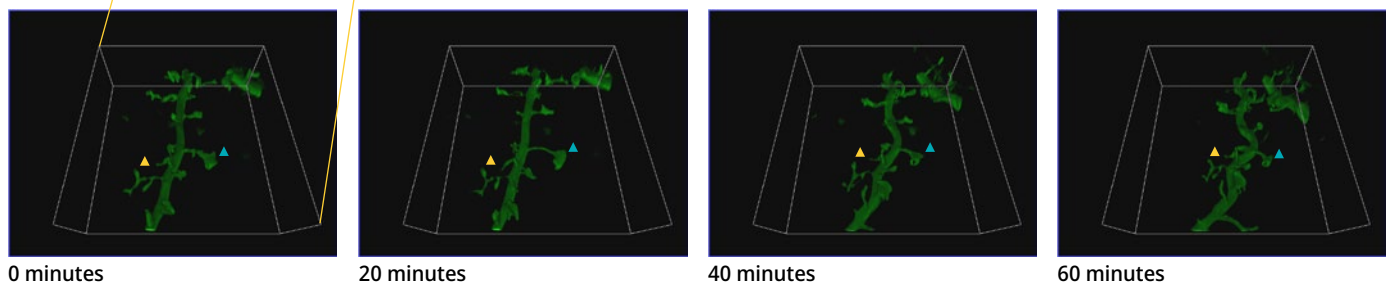

0 minutes

20 minutes

40 minutes

60 minutes

## Optical Sectioning

Based on a confocal optical system, Olympus super resolution technology enables optical sectioning to acquire clear super resolution images with reduced background.

**Mitotic epithelial cell** (chromosome: blue, tubulin: green, ZO1: red)

Image data courtesy of:  
Hatsuho Kanoh, Tomoki Yano, Sachiko Tsukita  
Graduate School of Frontier Biosciences and Graduate School of Medicine, Osaka University

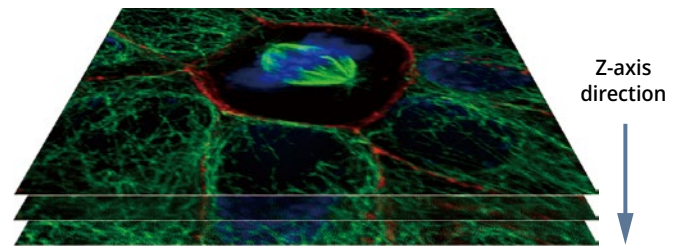

## Improved Z-Resolution

Our silicone immersion objectives are designed for deep tissue observation. Observation depth is negatively impacted by spherical aberration caused by refractive index mismatch. The refractive index of silicone oil ( $n_e \approx 1.40$ ) is close to that of living cells or cultured tissue slices ( $n_e \approx 1.38$ ), enabling super resolution imaging of internal cellular structures at tens of micrometers in depth with minimal spherical aberration.

### The Refractive Index Is Important with Deep Tissue Observation

In deep tissue observation, image quality depends on keeping the refractive index of the sample and immersion medium as close to each other as possible.

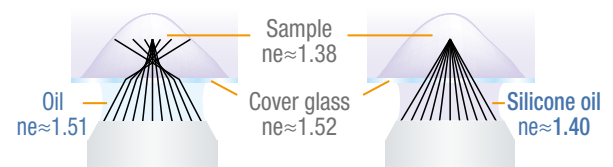

#### Oil immersion objective

When working with an oil immersion objective, the difference between the refractive index of the samples and oil results in spherical aberration in deep tissue, causing the resolution to deteriorate and fluorescence to become dim.

#### Silicone oil immersion objective

When working with a silicone immersion objective, the difference between the refractive index of the samples and silicone oil is minimal. This objective achieves brighter fluorescence images with higher resolution for deep tissue observation.

## Reduce Spherical Aberration

The remote correction collar unit is used to adjust the lens position within the objective to correct for spherical aberration caused by refractive index mismatch, resulting in dramatically improved signal, resolution, and contrast. The IX3-RCC unit works with any UIS2 objective that has a correction collar.



## Sharp Super Resolution Images

Our TruSight™ deconvolution works with super resolution images to create clear, sharp 3D images.

Mouse kidney tissue stained with Alexa Fluor 488

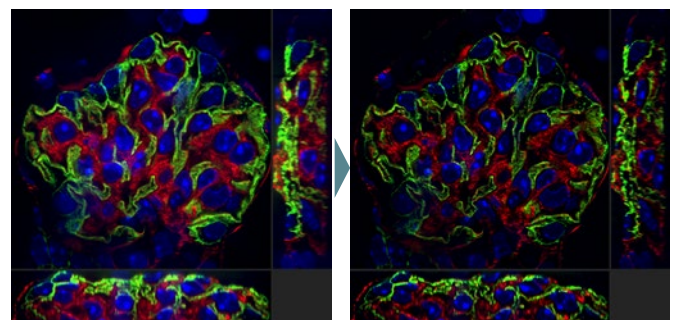

SpinSR10 image

SpinSR10 image improved using TruSight deconvolution

# A Flexible System That Helps Simplify Your Research

cellSens™ image analysis software supports the complex experiments conducted with the SpinSR10 system. The software's efficient workflows enable users to effectively manage their data and perform advanced analysis that helps unlock new insights. The system integrates easily into existing protocols without necessitating major changes; labs can continue using their existing sample and labeling protocols.

## One System, Three Imaging Modes

Researchers can use the imaging mode that most suits their sample. Users can switch between widefield, confocal, and super resolution, multicolor imaging with one click to locate areas of interest and then image fine structures.

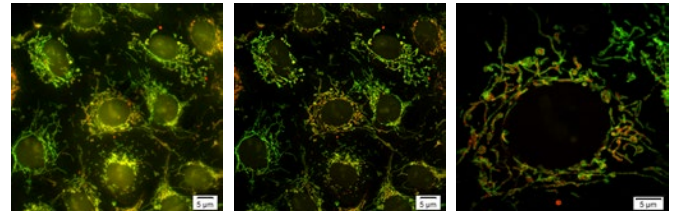

Widefield

Confocal

Super Resolution

## Easily Switch Observation Methods

The software makes it easy for you to change observation conditions. Switch between fluorescence channels, confocal, and super resolution just by clicking a button.



Observation Method

## Macro-to-Micro Observation

By easily switching observation methods and objective lenses on the software, it is possible to acquire macro images for observing the entire sample and micro images that enable detailed observation of the target area.

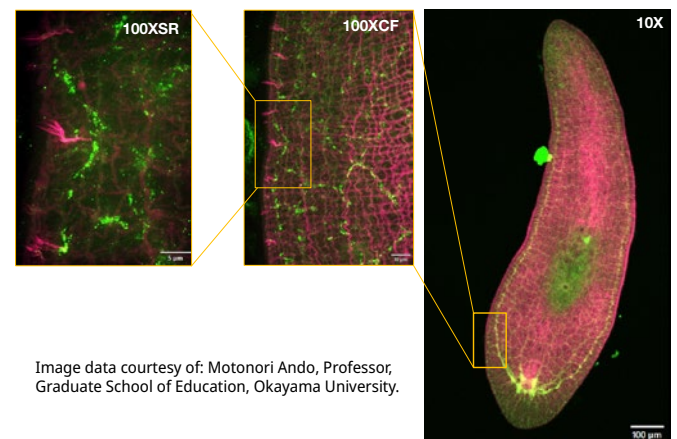

Image data courtesy of: Motonori Ando, Professor, Graduate School of Education, Okayama University.

## Manage Complex Experiments

The process manager makes it simple to acquire multicolor, Z-stack, and time-lapse images. The programmable graphic experiment manager (GEM) enables users to design more complex automation from a visual interface to support a wide variety of experimental imaging protocols and device triggering. Customize flexible experiment protocols that can be easily changed as needed anytime during the imaging process.



GEM



# Powerful, Intuitive Image Analysis

cellSens™ imaging software enables various types of numerical data to be extracted from images obtained using the software's image analysis functions. Straight line distance, boundary length, or the area of a polygon can all be measured. The following additional advanced measurements are also possible:

## Analyze Object Information

Analyze information about objects in your images, including the number of objects, area measurement, luminosity, and morphology.

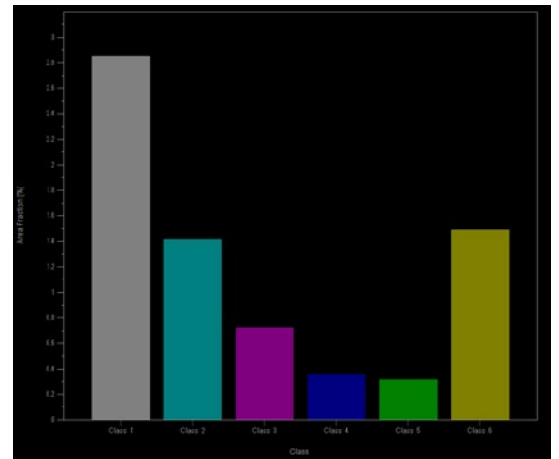
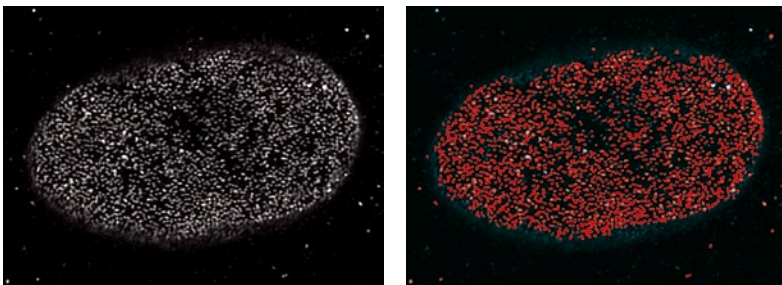

## Discriminate Spectrum Overlap

The colocalization function analyzes the fluorescent spectrum and discriminates between overlapping spectra.

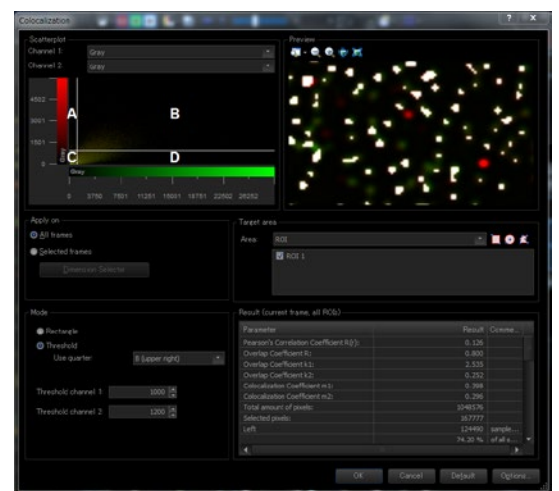
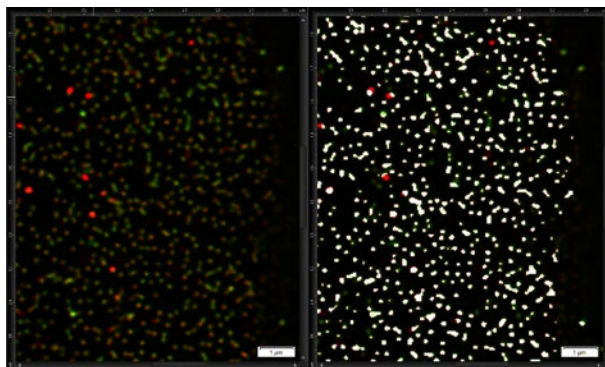

## Track Time-Lapse Imaging Data

During time-lapse imaging, the tracking function enables users to measure and analyze cell migration, division, and luminosity.

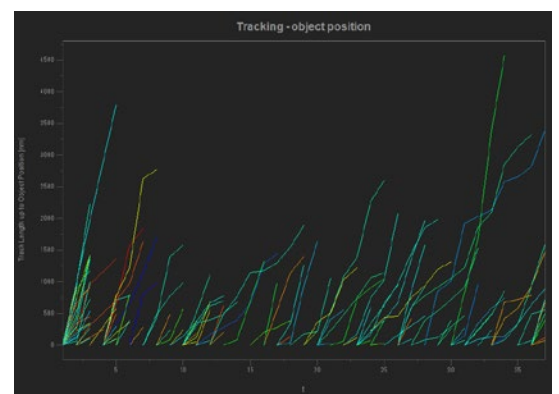
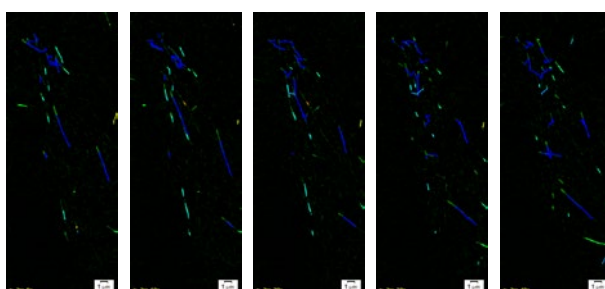

# SpinSR10 System Description

The SpinSR10 system is capable of performing widefield, confocal, and super resolution image observation quickly and easily.



SpinSR10 system diagram

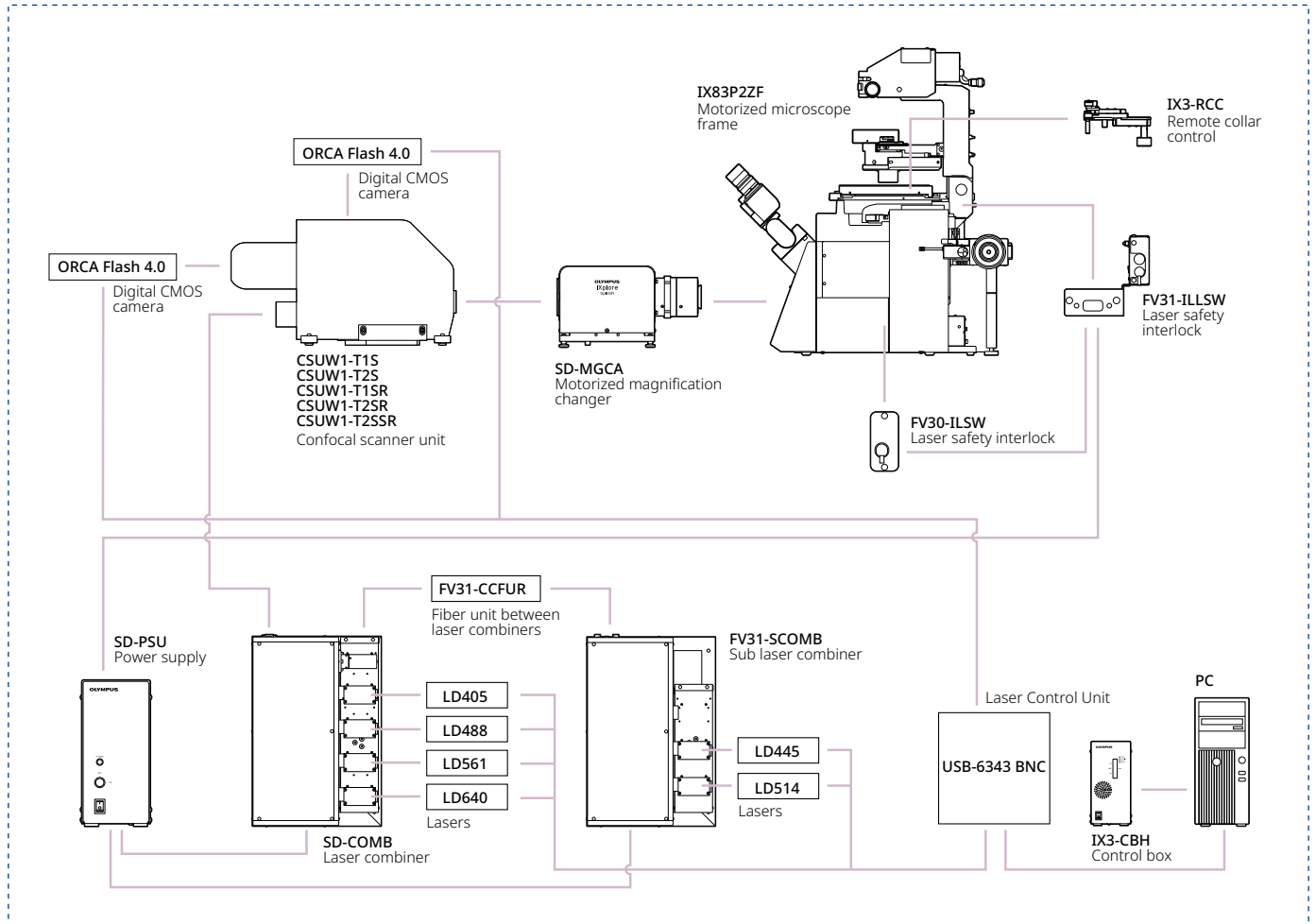

## SpinSR10 Specifications

		Super Resolution/Confocal Configuration	Confocal Configuration*	
Laser Lines		405 nm: 50 mW, 445 nm: 75 mW, 488 nm: 100 mW, 514 nm: 40 mW, 561 nm: 100 mW, 640 nm: 100 mW		
Laser Combiner		Main combiner: 405 nm, 488 nm, 561 nm, 640 nm + 1 line (445 nm or 514 nm) Sub combiner: 445 nm, 514 nm 2x Interlock shutter available		
Laser Light Control		Direct modulation, ON/OFF control and intensity modulation with individual laser lines		
Scanner	Yokogawa CSU-W1	Disk Unit	SoRa disk or 50 µm pinhole disk maximally 2 disks selectable	
		Camera Port	1 or 2 camera model**	
	Super Resolution Imaging	Acquisition Speed (Max.)	5 ms/f	-
		Optical Zoom	3.2X	-
		Optical Resolution***	SoRa disk: 110 nm 50 µm pinhole disk: 120 nm	-
		Field Number	5.9	-
	Regular Confocal Imaging	Acquisition Speed (Max.)	5 ms/f	
		Optical Zoom	1X	
		Field Number	18.8	
	Dichromatic Mirror		3 position (motorized slider)	
Filter Wheel (emission)		10 position (motorized wheel)		
Imaging Sensor		HAMAMATSU ORCA Flash 4.0 V3 (CameraLink)		
Motorized Microscope		IX83P2ZF motorized inverted microscope		
Microscope	Objectives for Super Resolution	UPLSAPO60XS2, UPLSAPO100XS, UPLAPO60XOHR, UPLAPO100XOHR, UPLXAPO60XO, UPLXAPO100XO, PLAPON60XOSC2	-	
	Super Resolution Adapter	Confocal/super resolution light path changer (Motorized)		
Imaging Software	cellSens Dimension	Multi-dimensional acquisition and analysis		
		Super resolution imaging module	-	

\*Confocal configuration is the system without the super resolution function. Can be upgraded to the super resolution/confocal configuration.

\*\*Restrictions depend on the disk unit combinations.

\*\*\*Typical experimental FWHM values with UPLSAPO100XS at 488 nm excitation. SoRa disk with 40 nm diameter beads and 50 µm pinhole disk with 100 nm diameter beads.

## Dimensions

(unit: mm)

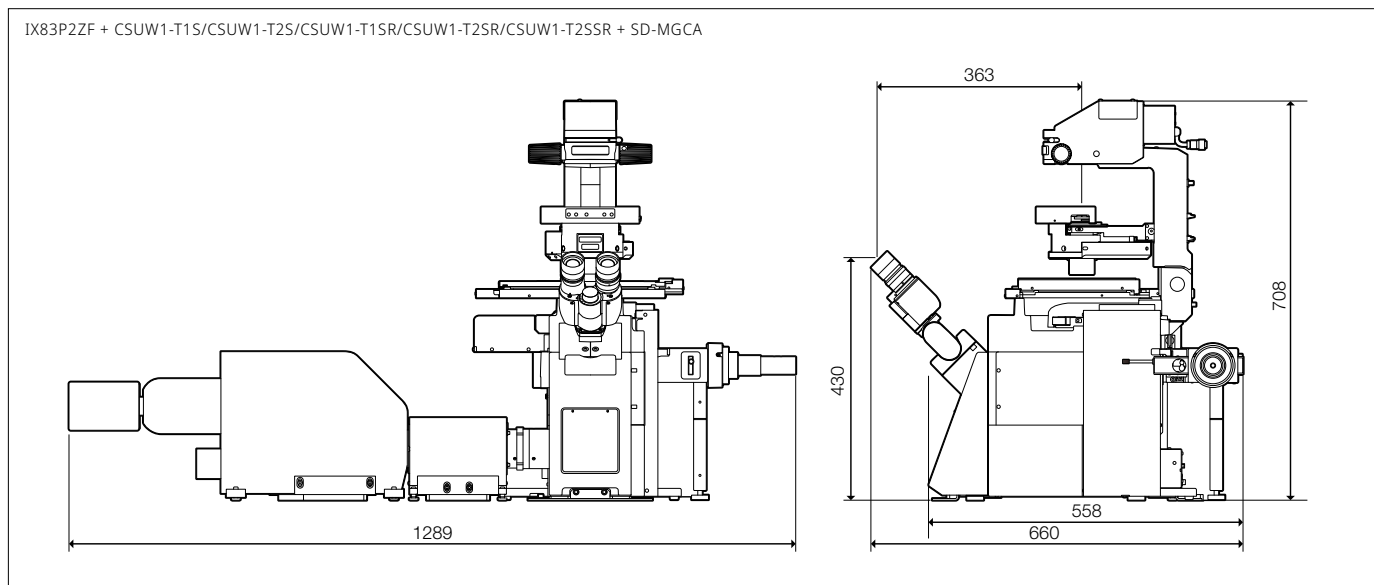



[EvidentScientific.com](http://EvidentScientific.com)

**EVIDENT**

**EVIDENT CORPORATION**  
Shinjuku Monolith, 2-3-1 Nishi-Shinjuku, Shinjuku-ku, Tokyo 163-0910, Japan

**OLYMPUS**

**Cover image:** Cultured epithelial cell.  
Image data courtesy of: Dr. Huiwen Hao, et al., Standard Imaging Co.,Ltd. and Sun Lab, College of Future Technology, PKU.

- **EVIDENT CORPORATION is ISO14001 certified.**
- **EVIDENT CORPORATION is ISO9001 certified.**
- **Illumination devices for microscope have suggested lifetimes. Periodic inspections are required. Please visit our website for details.**

- All company and product names are registered trademarks and/or trademarks of their respective owners.
- Images on the PC monitors are simulated.
- Specifications and appearances are subject to change without any notice or obligation on the part of the manufacturer.
- HeLa cells are one of the most important and well known cell strains for medical research and scientific development. They have contributed to major discoveries in immunology, infectious diseases, and cancer research, and have raised serious questions about ethics in the medical field. Visit [henriettalacksfoundation.org](http://henriettalacksfoundation.org) for more information on the life of Henrietta Lacks and her contributions to modern medicine.